

CRAFTING
BEAUTY
for a lifetime
2026

Ritzwell

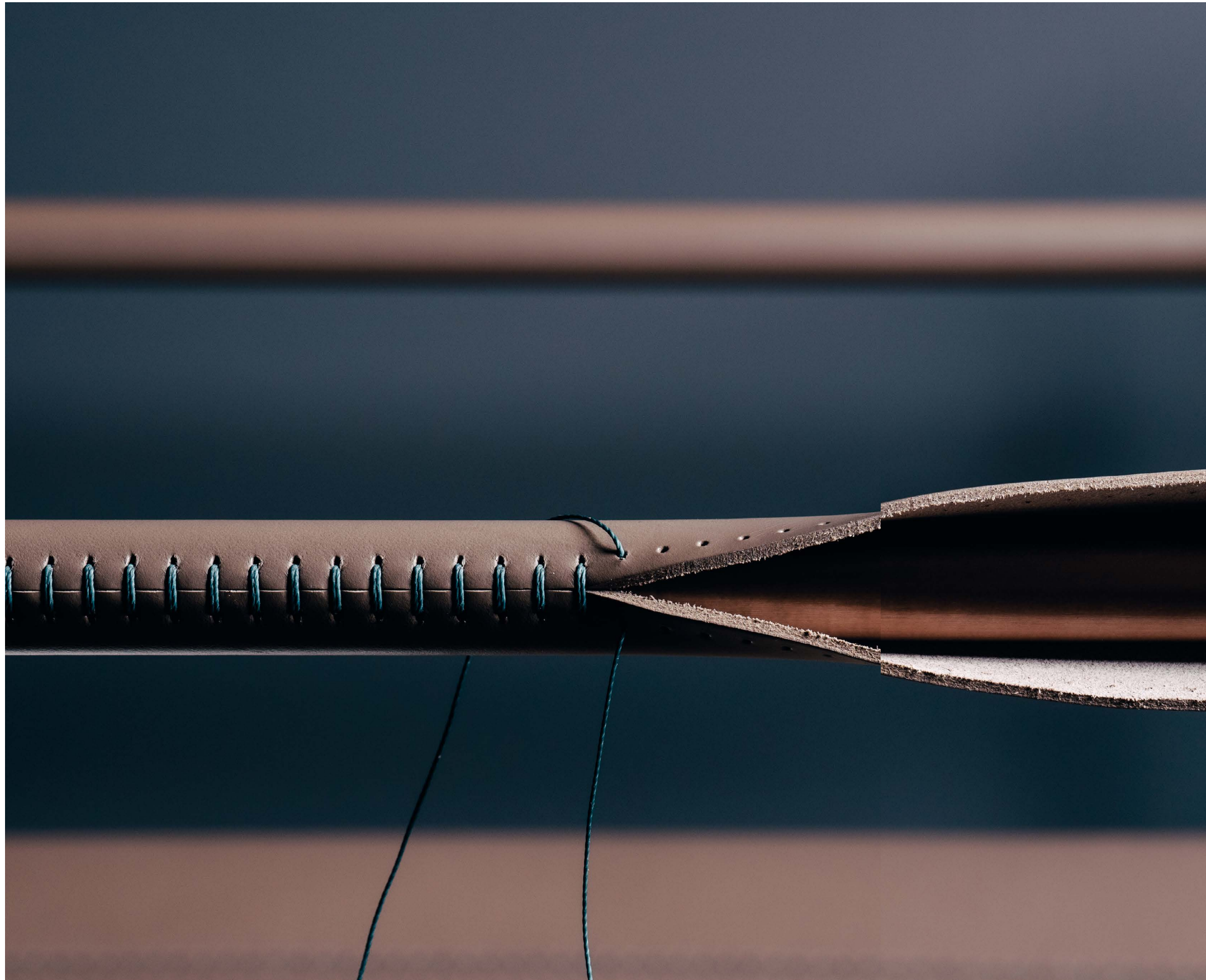

Dear connoisseur of fine living,
The world outside grows louder, faster,
less certain of where it is headed. Yet
between these pages lies a place of
stillness. Each piece in this collection
is designed to restore balance — to
answer the chaos beyond your walls
with quiet, enduring harmony. Now, let
the visit begin. Turn the page and find
sanctuary in the meditative world of
Ritzwell.



NEWS 2026

- 06 | GT TABLE
- 18 | VESPER ARMCHAIR

ICONS

- 24 | CHAIRS
- 26 | EASY CHAIRS
- 28 | SIDE & COFFEE TABLES
- 30 | BENCHES & STOOLS
- 32 | TABLES
- 36 | STORAGES
- 38 | SOFAS

TECHNICAL DATA

- 43 | NEWS
- 44 | CHAIRS
- 46 | CHAIRS, BENCHES & STOOLS
- 47 | TABLES
- 50 | SOFAS
- 55 | STORAGES



NEWS 2026



Detail_ SIDE TABLE 2026
TABLE TOP: NATURAL STONE (MARRON MARINACE)
FRAME: THICK LEATHER (BLACK) WRAPPED HAIRLINE STAINLESS STEEL (SHINY BRONZE)

GT TABLE DESIGN SHINSAKU MIYAMOTO

SIDE TABLE 2026

TABLE TOP: NATURAL STONE (ZIMBABWE)

FRAME: THICK LEATHER (BLACK) WRAPPED STAINLESS STEEL METALLIC (SILKVEIL GOLD)



BALANCE OUT OF CHAOS

Perfect symmetry is a human invention; the universe favors irregularity. Japanese philosophy embraces natural chaos to create deep balance. Encounter the GT Table, and the concept materializes.

Observe the base. Steel legs intersect in deliberate asymmetry, forming a visual illusion that shifts with your perspective. Whether taking the form of a sprawling lounge table, an intimate coffee table, or a quiet side table, the frame anchors the interior, asking you to slow down.

Approach the split tabletop and trace the chamfered edge. A tactile journey begins, inviting you to orchestrate a personal equilibrium. Let your hands explore one of the endless finish combinations—perhaps the porous, ivory travertine of Romano with its otherworldly aura, or Marron Marinace webbed with labyrinthine veins.

Follow the stone boundary to the corner. Industrial strength yields to warmth as thick leather wraps the metal framework, secured by meticulous stitches. Each loop holds the devotion of Fukuoka artisans. Such unhurried excellence, born beneath the rising sun, arrives quietly across oceans as a rarity.

Trace the heavy thread. While the outside world accelerates, ancient techniques remain unaltered. Centuries of inherited knowledge guide the maker's needle. Whenever the daily rush feels overwhelming, running a hand along the leather acts as a grounding exercise that helps you reclaim profound inner peace.

Above_ GT SIDE TABLE 2026
TABLE TOP: NATURAL STONE (MARRON MARINACE)
FRAME: THICK LEATHER (BLACK) WRAPPED HAIRLINE STAINLESS STEEL (SHINY BRONZE)

Below_ GT SIDE TABLE 2026
TABLE TOP: NATURAL STONE (ROMANO)
FRAME: STAINLESS STEEL METALLIC (SILKVEIL COPPER)



Detail_ GT SIDE TABLE 2026
TABLE TOP: NATURAL STONE (PORTLAND TAUPE)
FRAME: THICK LEATHER (TERRACOTTA) WRAPPED STAINLESS STEEL METALLIC (SILKVEIL COPPER)



Detail_ GT SIDE TABLE 2026
TABLE TOP: NATURAL STONE (ROMANO)
FRAME: STAINLESS STEEL METALLIC (SILKVEIL COPPER)



GT COFFEE TABLE 2026
TABLE TOP: NATURAL STONE TWO-TONE (ROMANO)
FRAME: THICK LEATHER (ECRU) WRAPPED STAINLESS STEEL METALLIC (SILKVEIL COPPER)





GT COFFEE TABLE 2026
TABLE TOP: NATURAL STONE TWO-TONE (ZIMBABWE)
FRAME: THICK LEATHER (BLACK) WRAPPED STAINLESS STEEL METALLIC (SILKVEIL GOLD)





GT LOUNGE TABLE 2026
TABLE TOP: NATURAL STONE (VERDE MACEDONIA)
FRAME: STAINLESS STEEL METALLIC (SILKVEIL GOLD)

GT LOUNGE TABLE 2026
TABLE TOP: NATURAL STONE
TWO-TONE (ZIMBABWE)
FRAME: THICK LEATHER (BLACK)
WRAPPED STAINLESS STEEL METALLIC
(SILKVEIL GOLD)



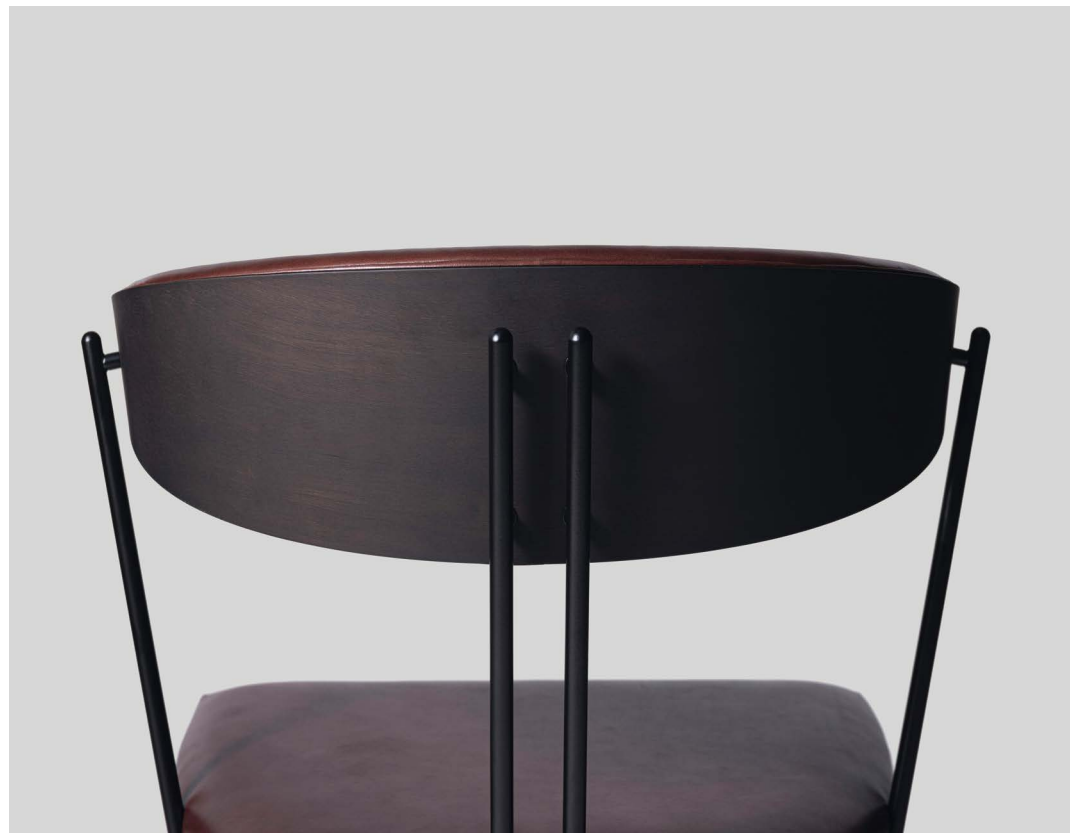

VESPER ARMCHAIR_DESIGN ATELIER D.Q.

ARMCHAIR 2026

FRAME: STEEL (BLACK) - SEAT AND BACK: LEATHER

BACK PANEL AND LEG: WALNUT POLYURETHANE FINISH (MATTE GEN)





THE EQUILIBRIUM OF DUSK

As day exhales and twilight settles, shadows stretch across the room. Observe the silhouette cast against a quiet wall. A solid crescent floats above slender lines. The projection announces the rise of VESPER—the evening star—capturing the precise equilibrium where light and dark merge.

Step forward, and the physical reality of the armchair emerges. Bare steel rods carry the weight, allowing the leather backrest and the wooden frame to appear almost weightless. Architectural poise unites contrasting materials into profound balance.

This unity is anchored by a single detail. Look closely at the hand-sewn stitches finishing the leather. Each deliberate loop holds the memory of craftsmen in Fukuoka, a quiet testament to an object conceived and created in Japan. This meticulous thread alone imbues the armchair with unspoken rarity.

Sit, and the visual interplay dissolves into deep physical composure. Instead of conventional armrests, the upholstered crescent gently extends forward in a continuous, welcoming embrace.

Posture naturally relaxes into the curve. As your fingers find the hand-sewn stitches, the spirit of centuries-old Japanese craftsmanship grounds you in the present moment.

Through years of shared evenings, wood and leather will absorb the rhythm of your life. A living object suspended on steel, aging beautifully while holding you in enduring equilibrium.

All the images:
VESPER ARMCHAIR
FRAME: STAINLESS STEEL METALLIC (SILKVEIL COPPER)
SEAT AND BACK: LEATHER
BACK PANEL AND LEG: WALNUT POLYURETHANE FINISH (mSB)



THE SLOW EMERGENCE OF BEAUTY: BUILDING A CELEBRATED HERITAGE

While the world chases fleeting novelty, Ritzwell favors the slow emergence of beauty. We never force innovation. Each year, only a few select designs are refined to build upon a celebrated heritage. Only the most profound concepts earn a place in the collection.

Patience preserves the essential character of RIVAGE and BLAVA chairs alongside the sculptural CLAUDE chair series. Global accolades, including Red Dot and iF Design Awards, confirm the status of the LIGHT FIELD Sofa, GQ Table, JK Table, MO BRIDGE Bench, and JABARA Sideboard as enduring icons. Celebrated across continents, the collection represents a quiet, uncompromising excellence.

Award-winning forms act as physical anchors. Unwavering presence deepens with every interaction, transforming functional objects into a living legacy.

ICONS



CONSTANTINO ARMCHAIR 2024
FRAME: OAK POLYURETHANE FINISH (MATTE WHITE)
SEAT AND BACK: LEATHER | ARM AND PIPING: LEATHER



CLAUDE ARMCHAIR 2013
FRAME: WALNUT OIL FINISH
SEAT AND BACK: FABRIC



VESPER LOUNGE CHAIR 2025
FRAME: HAIRLINE STAINLESS STEEL (ANTIQUÉ GRAY)
AND THICK LEATHER (ECRU) | SEAT AND BACK: FABRIC



MARCEL CHAIR 2013
FRAME: WALNUT OIL FINISH
BACK PANEL: WALNUT POLYURETHANE FINISH
SEAT AND BACK: LEATHER



ICONS | EASY CHAIRS



BLAVA EASY CHAIR 2016
FRAME: OAK OIL FINISH (WHITE)
CUSHION: LEATHER | BELT: THICK LEATHER (BLACK)



BEATRIX HIGH BACK EASY CHAIR 2020
FRAME: WALNUT OIL FINISH | SEAT AND BACK: FABRIC
SHELL: FABRIC | PIPING: LEATHER



RIVAGE EASY CHAIR 2016
FRAME: WALNUT OIL FINISH
SEAT AND BACK: LEATHER



JK COFFEE TABLE 2024
TABLE TOP: WALNUT OIL FINISH
LEG: STEEL (BLACK)



GQ SIDE TABLE 2023
TABLE TOP: WALNUT OIL FINISH
FRAME: THICK LEATHER (VINTAGE BROWN)
WRAPPED HAIRLINE STAINLESS STEEL (SHINY BRONZE)



JK COFFEE TABLE 2024
TABLE TOP: WALNUT OIL FINISH
LEG: STEEL (BLACK)



JK SIDE TABLE 2019
TABLE TOP: WALNUT OIL FINISH
LEG: HAIRLINE STAINLESS STEEL
(ANTIQUÉ BRASS)



JK SIDE TABLE 2019
TABLE TOP: WALNUT OIL FINISH
LEG: HAIRLINE STAINLESS STEEL
(SHINY BRONZE)

ICONS | SIDE & COFFEE TABLES



ICONS | BENCHES & STOOLS



MT BENCH 2020
SEAT: WALNUT OIL FINISH
FRAME: HAIRLINE STAINLESS STEEL (SHINY BRONZE)
BELT: THICK LEATHER (TAUPE GRAY)



VINCENT STOOL 2016
FRAME: OAK OIL FINISH (WHITE)
BELT: THICK LEATHER (BLACK)



MO BRIDGE COUNTER STOOL 2023
FRAME: OAK POLYURETHANE FINISH (MATTE TAUPE GRAY)
BELT: THICK LEATHER (BLACK)



MO BRIDGE BENCH 2021
FRAME: WALNUT OIL FINISH
BELT: THICK LEATHER (TAUPE GRAY)





MCM DINING TABLE 2015
TABLE TOP AND LEG: WALNUT OIL FINISH
FRAME: STEEL (BLACK)



MT DINING TABLE 2021
TABLE TOP: OAK POLYURETHANE FINISH (MATTE BLACK)
FRAME: HAIRLINE STAINLESS STEEL (ANTIQUÉ GRAY)



MTM DINING TABLE 2023
TABLE TOP: OAK POLYURETHANE FINISH (MATTE BLACK)
FRAME: HAIRLINE STAINLESS STEEL (ANTIQUÉ GRAY)



MO SIDE TABLE 2016
TABLE TOP AND LEG: WALNUT OIL FINISH (WHITE)



MO DINING TABLE 2016
TABLE TOP AND LEG: OAK POLYURETHANE FINISH (BLACK)



MO COFFEE TABLE 2016
TABLE TOP AND LEG: OAK POLYURETHANE FINISH (BLACK)



JABARA SIDEBOARD 2018
BODY: OAK POLYURETHANE FINISH (MATTE WHITE)
BASE: STEEL (BLACK)



JABARA SIDEBOARD 2018
BODY: WALNUT POLYURETHANE FINISH
BASE: STEEL (BLACK)



JABARA AV BOARD 2019
BODY: OAK POLYURETHANE FINISH
BASE: STEEL (BLACK)

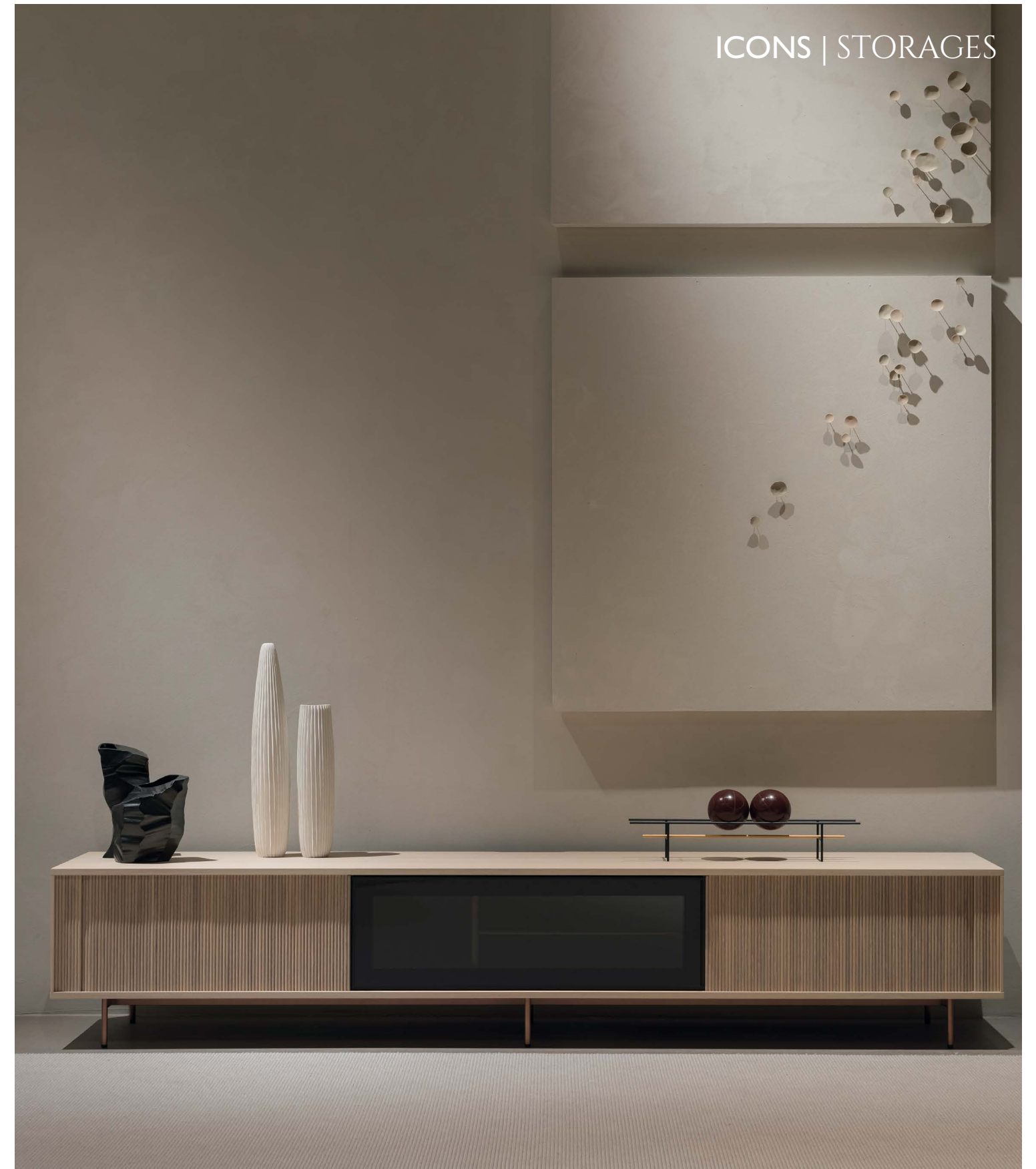





VELAR MODULAR SOFA 2025
FRAME AND CUSHION: FABRIC
PIPING: ARTIFICIAL SUEDE LEATHER
LEG: STEEL (BLACK)



LIGHT FIELD 3 SEATER SOFA 2014
FRAME: THICK LEATHER COVERED PANELS
PADDING AND CUSHION: FABRIC
LEG: HAIRLINE STAINLESS STEEL (SHINY HAIRLINE)



DIANA 3 SEATER SOFA 2013
FRAME: WALNUT OIL FINISH
FRAME COVER: LEATHER | CUSHION: FABRIC



LIGHT FIELD 3 SEATER SOFA 2014
FRAME: THICK LEATHER COVERED PANELS
PADDING AND CUSHION: FABRIC
LEG: HAIRLINE STAINLESS STEEL (ANTIQUE GRAY)

TECHNICAL DATA

06 |

GT TABLE

Design: SHINSAKU MIYAMOTO

Frame in thick leather black, taupe gray, ecru, amber, terracotta, burgundy, vintage brown and dark brown wrapped steel powder coating with black and hairline stainless steel acrylic urethane coating with 6 colors, classic rose, shiny brass, antique brass, shiny bronze, antique gray and shiny hairline and stainless steel metallic with 2 colors, silkveil copper and silkveil gold
Top in natural stone and engineered quartz

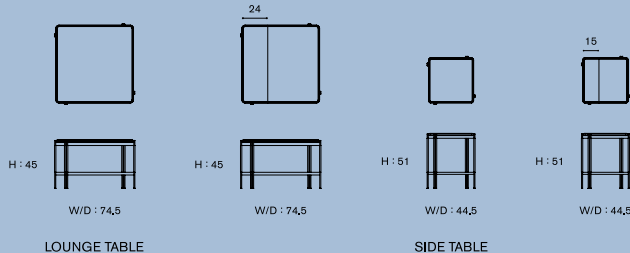
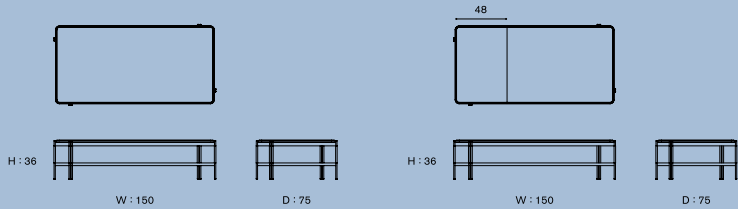
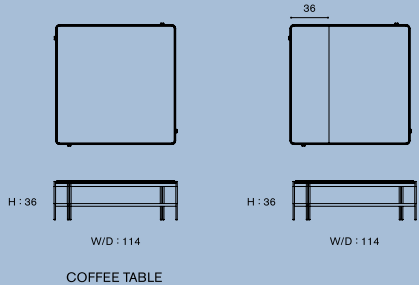

18 |

VESPER ARMCHAIR

Design: ATELIER D.Q.

Seat and back in fabric and leather
Frame in steel powder coating with black and hairline stainless steel acrylic urethane coating with 6 colors, classic rose, shiny brass, antique brass, shiny bronze, antique gray and shiny hairline and stainless steel metallic with 2 colors, silkveil copper and silkveil gold and in thick leather black, taupe gray, ecru, amber, terracotta, burgundy, vintage brown and dark brown
Back panel and leg in walnut, oak

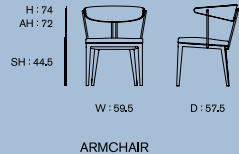

24 | VESPER LOUNGE CHAIR
 Design: ATELIER D.Q.
 Seat and back in fabric and leather
 Frame in steel powder coating with black and hairline stainless steel acrylic urethane coating with 6 colors, classic rose, shiny brass, antique brass, shiny bronze, antique gray and shiny hairline and stainless steel metallic with 2 colors, silkveil copper and silkveil gold and stainless steel metallic and in thick leather black, taupe gray, ecru, amber, terracotta, burgundy, vintage brown and dark brown

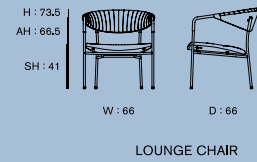

LOUNGE CHAIR

24 | CONSTANTINO
 Design: SHINSAKU MIYAMOTO
 Seat and cushion in fabric and leather
 Frame in walnut, oak
 Arm and piping in fabric, leather and thick leather black, taupe gray, ecru, amber, terracotta burgundy, vintage brown and dark brown

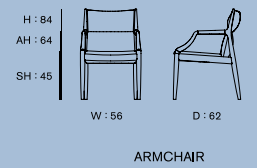

ARMCHAIR

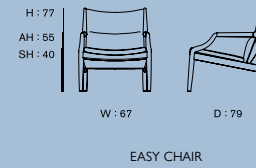

EASY CHAIR

MERCURY
 Design: SHINSAKU MIYAMOTO
 Seat and cushion in fabric and leather
 Frame in steel powder coating with black and hairline stainless steel acrylic urethane coating with 6 colors, classic rose, shiny brass, antique brass, shiny bronze, antique gray and shiny hairline and stainless steel metallic with 2 colors, silkveil copper and silkveil gold
 Arm and back in fabric, leather and thick leather black, taupe gray, ecru, amber, terracotta, burgundy, vintage brown and dark brown

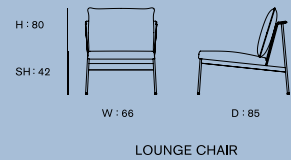

LOUNGE CHAIR

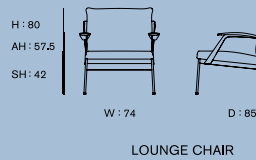

LOUNGE CHAIR

VERSE
 Design: SHINSAKU MIYAMOTO
 Seat and cushion in fabric and leather
 Frame in walnut, oak and thick leather black, taupe gray, ecru, amber, terracotta, burgundy, vintage brown and dark brown

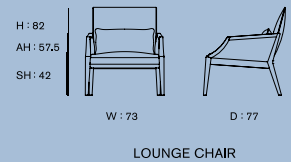

LOUNGE CHAIR

24 | CLAUDE
 Design: SHINSAKU MIYAMOTO
 Seat and back in fabric and leather
 Frame in walnut, oak

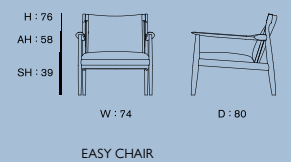

EASY CHAIR

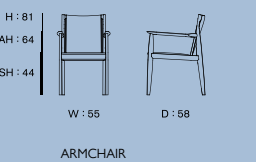

ARMCHAIR

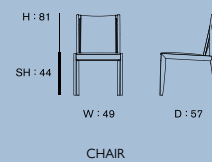

CHAIR

24 | MARCEL
 Design: SHINSAKU MIYAMOTO
 Seat and back in fabric and leather
 Frame in walnut, oak

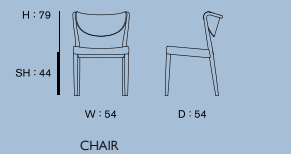

CHAIR

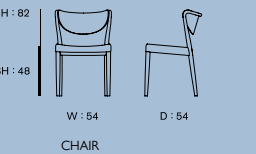

CHAIR

JK
 Design: JUN KAMAHARA
 Seat in fabric and leather for ARMCHAIR and thick leather for EASY CHAIR
 Back in thick leather
 black, taupe gray, ecru, amber, terracotta, burgundy, vintage brown and dark brown
 Frame in walnut, oak for ARMCHAIR and hairline stainless steel acrylic urethane coating with 6 colors for EASY CHAIR, classic rose, shiny brass, antique brass, shiny bronze, antique gray and shiny hairline and stainless steel metallic with 2 colors, silkveil copper and silkveil gold

"Hand stitch" available for EASY CHAIR

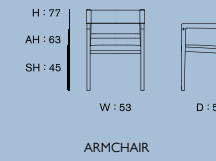

ARMCHAIR

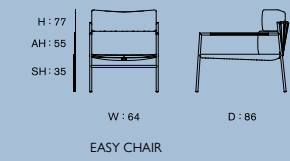

EASY CHAIR

27 | RIVAGE
 Design: ATELIER D.Q.
 Seat and back in fabric and leather
 Frame in walnut, oak for EASY CHAIR, ARMCHAIR, STOOL
 steel powder coating with black and hairline stainless steel acrylic urethane coating with 6 colors for LOUNGE CHAIR, classic rose, shiny brass, antique brass, shiny bronze, antique gray and shiny hairline and stainless steel metallic with 2 colors, silkveil copper and silkveil gold
 Arm in walnut, oak for LOUNGE CHAIR

"Hand stitch" available for back in leather, except for STOOL

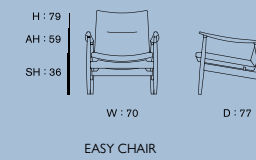

EASY CHAIR

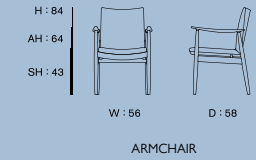

ARMCHAIR



STOOL

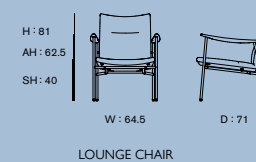

LOUNGE CHAIR

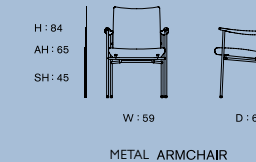

METAL ARMCHAIR

27 | BLAVA
 Design: ATELIER D.Q.
 Seat and back in removable fabric and leather
 Belt in thick leather
 black, taupe gray, ecru, amber, terracotta, burgundy, vintage brown and dark brown
 Frame in walnut, oak

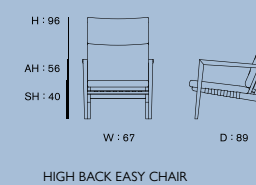

HIGH-BACK EASY CHAIR

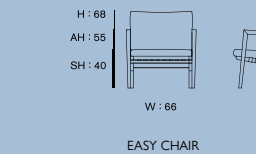

EASY CHAIR



OTTOMAN

LUPIN
 Design: ATELIER D.Q.
 Seat and back in fabric and leather
 Frame in walnut, oak
 Outside of seat and back in thick leather black, taupe gray, ecru, amber, terracotta, burgundy, vintage brown and dark brown

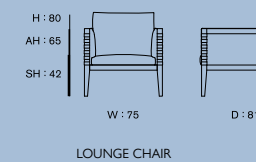

LOUNGE CHAIR

27 |
BEATRIX
 Design: SHINSAKU MIYAMOTO
 Seat and back in fabric and leather
 Frame in walnut, oak
 Shell in thick leather
 black, taupe gray, ecru, amber, terracotta,
 burgundy, vintage brown and dark brown

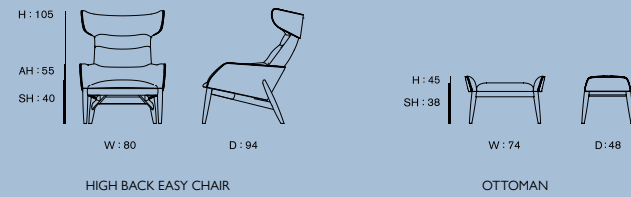

HIGH BACK EASY CHAIR

OTTOMAN

31 |
MT
 Design: SHINSAKU MIYAMOTO
 Seat in walnut, oak with thick leather webbing
 black, taupe gray, ecru, amber, terracotta,
 burgundy, vintage brown and dark brown
 Frame in steel powder coating with black
 and hairline stainless steel acrylic urethane coating
 with 6 colors, classic rose, shiny brass, antique brass,
 shiny bronze, antique gray and shiny hairline
 and stainless steel metallic with 2 colors, silkveil
 copper and silkveil gold

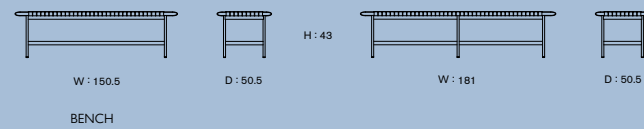

BENCH

31 |
VINCENT
 Design: RITZWELL
 Seat with thick leather webbing
 black, taupe gray, ecru, amber, terracotta, burgundy,
 vintage brown and dark brown
 Frame in walnut, oak



STOOL

31 |
MO BRIDGE
 Design: SHINSAKU MIYAMOTO
 Seat in walnut, oak with thick leather webbing
 black, taupe gray, ecru, amber, terracotta, burgundy,
 vintage brown and dark brown
 Frame in walnut, oak
 Top in walnut, oak upholstered in thick leather
 black, taupe gray, ecru, amber, terracotta, burgundy,
 vintage brown and dark brown

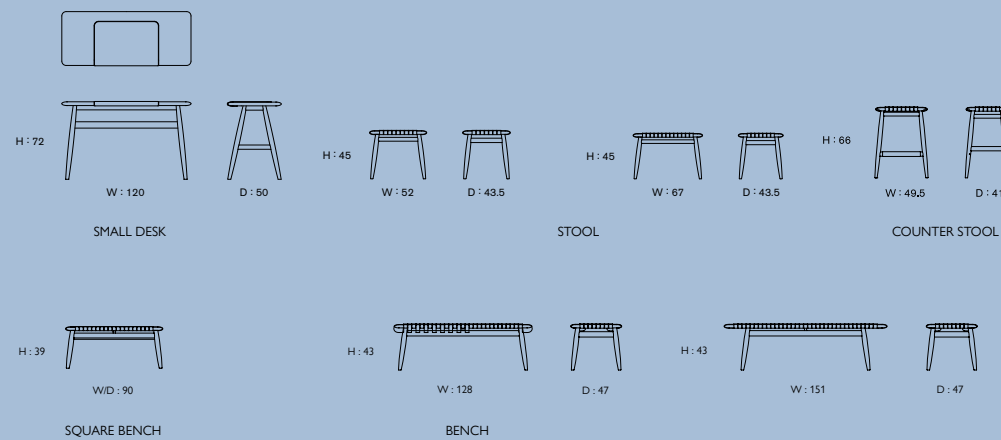

SMALL DESK

STOOL

COUNTER STOOL

SQUARE BENCH

BENCH

28 |
GQ TABLE
 Design: SHINSAKU MIYAMOTO
 Frame in thick leather black, taupe gray, ecru,
 amber, terracotta, burgundy, vintage brown and
 dark brown wrapped steel powder coating with
 black and hairline stainless steel acrylic urethane
 coating with 6 colors, classic rose, shiny brass,
 antique brass, shiny bronze, antique gray and shiny
 hairline and stainless steel metallic with 2 colors,
 silkveil copper and silkveil gold
 Top in solid oak, walnut

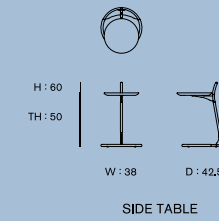

SIDE TABLE

LEEWISE EXCLUSIVE
 Design: JUNICHIRO WATANABE & RITZWELL
 Top in oak
 Leg frame in white ash

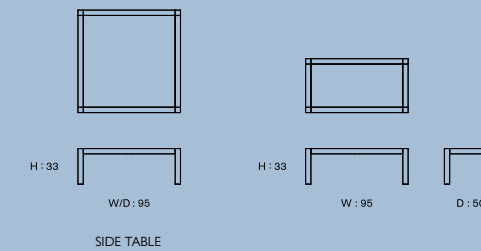

SIDE TABLE

28 |
JK TABLE
 Design: JUN KAMAHARA
 Top in solid walnut
 Leg in steel powder coating with black
 and hairline stainless steel acrylic urethane
 coating with 6 colors, classic rose, shiny
 brass, antique brass, shiny bronze, antique
 gray and shiny hairline and stainless steel
 metallic with 2 colors, silkveil copper and
 silkveil gold

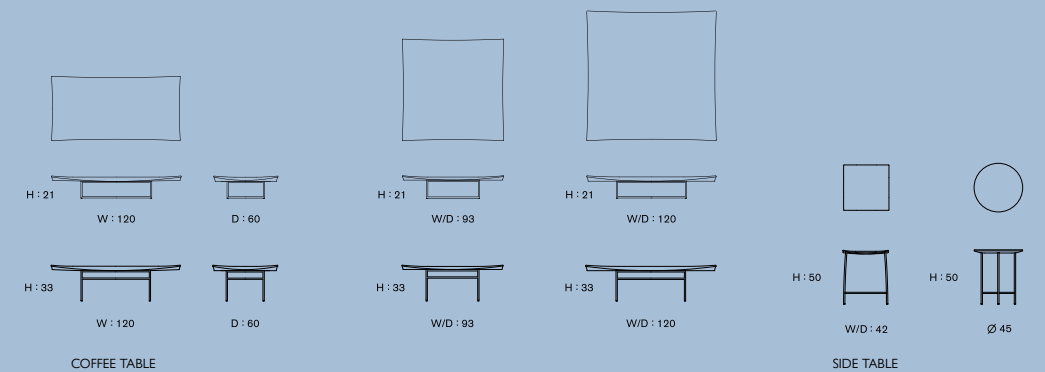

COFFEE TABLE

SIDE TABLE

MT COFFEE TABLE
 Design: SHINSAKU MIYAMOTO
 Top in solid oak, walnut
 Frame in steel powder coating with black
 and hairline stainless steel acrylic urethane coating
 with 6 colors, classic rose, shiny brass, antique brass,
 shiny bronze, antique gray and shiny hairline
 and stainless steel metallic with 2 colors, silkveil
 copper and silkveil gold

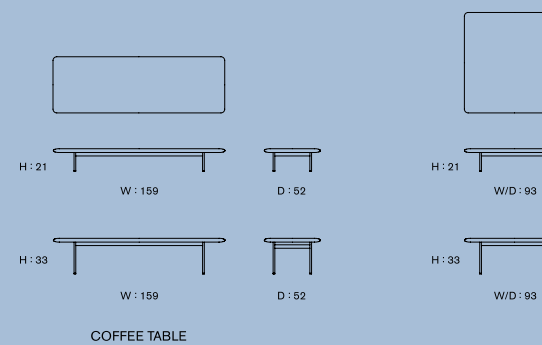

COFFEE TABLE

34 | MT TABLE
 Design: SHINSAKU MIYAMOTO
 Top in solid oak, walnut
 Frame in steel powder coating with black and hairline stainless steel acrylic urethane coating with 6 colors, classic rose, shiny brass, antique brass, shiny bronze, antique gray and shiny hairline and stainless steel metallic with 2 colors, silkveil copper and silkveil gold

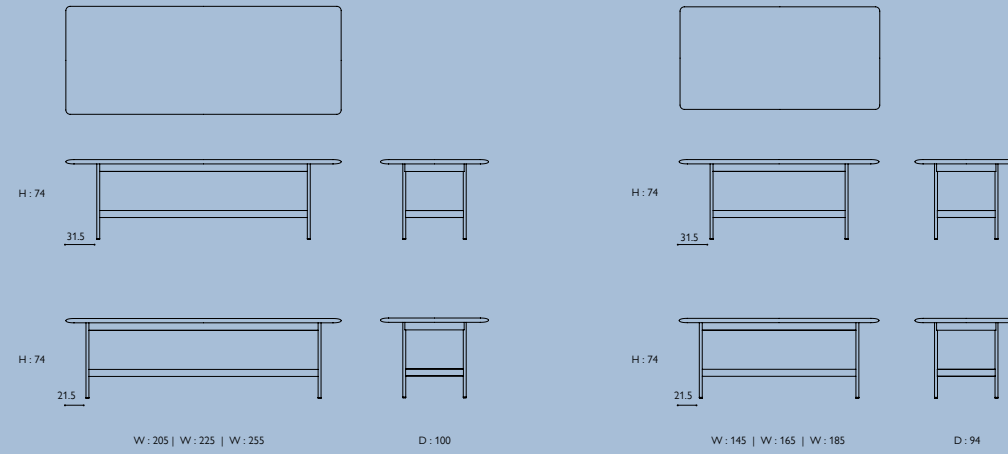

34 | MTM TABLE
 Design: RITZWELL
 Top in solid oak, walnut
 Frame in steel powder coating with black and hairline stainless steel acrylic urethane coating with 6 colors, classic rose, shiny brass, antique brass, shiny bronze, antique gray and shiny hairline and stainless steel metallic with 2 colors, silkveil copper and silkveil gold

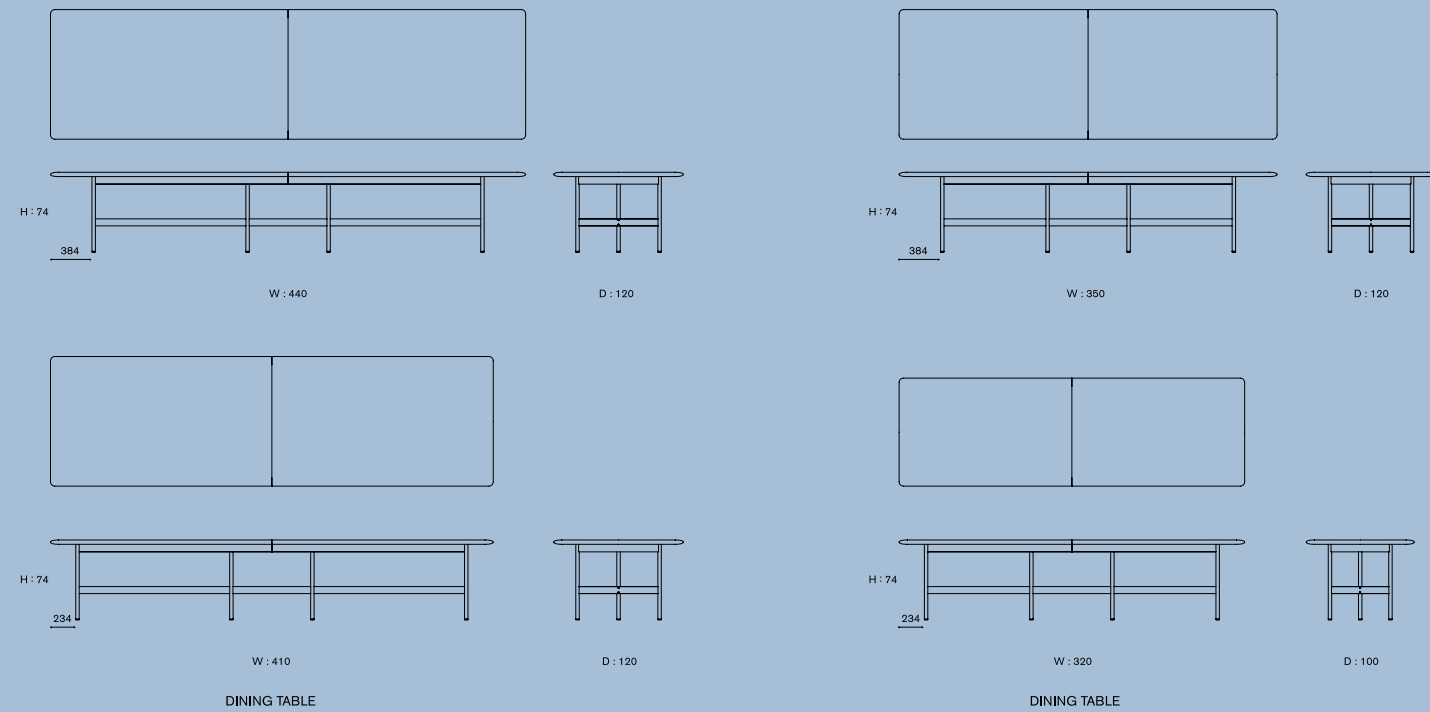

34 | MCM TABLE
 Design: SHINSAKU MIYAMOTO
 Top and leg in solid walnut
 Frame in steel powder coating with black

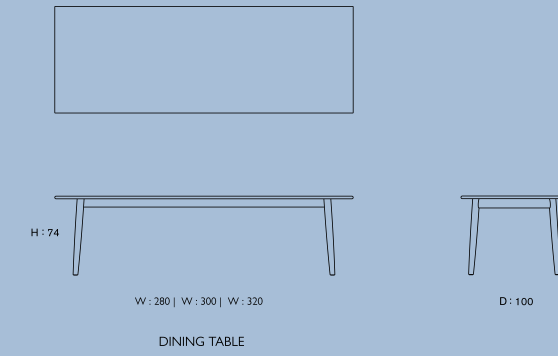

35 | MO TABLE
 Design: SHINSAKU MIYAMOTO
 Top in solid oak, walnut
 Leg in solid oak

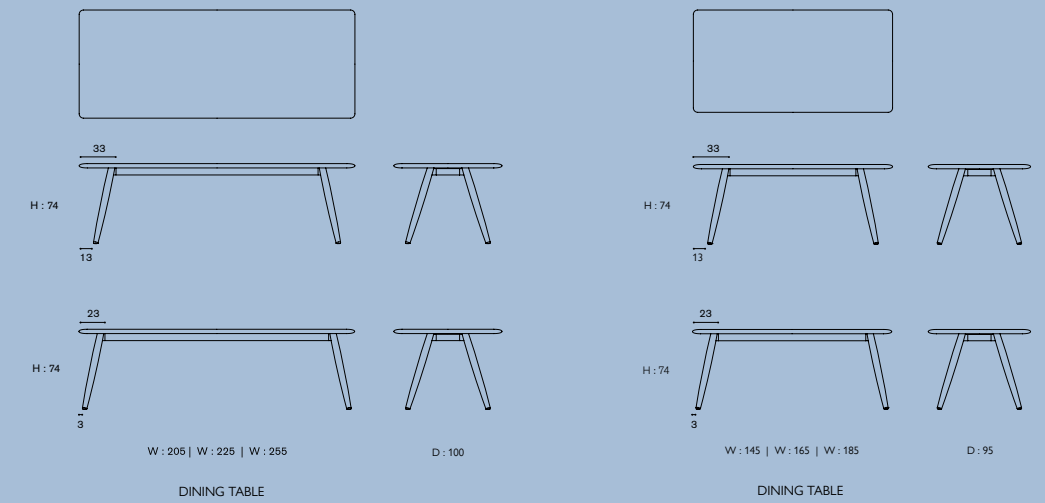
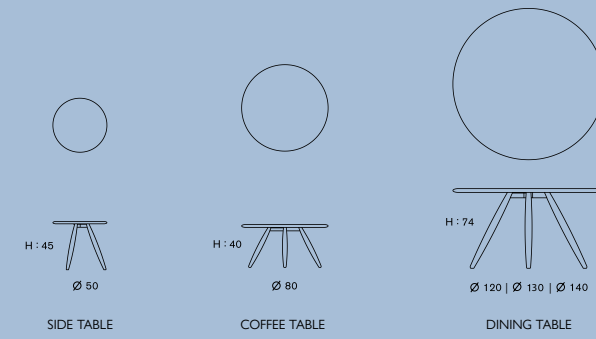

OS TABLE
 Design: RITZWELL
 Top in solid walnut, oak
 Leg in steel powder coating with black and hairline stainless steel acrylic urethane coating with 6 colors, classic rose, shiny brass, antique brass, shiny bronze, antique gray and shiny hairline and stainless steel metallic with 2 colors, silkveil copper and silkveil gold

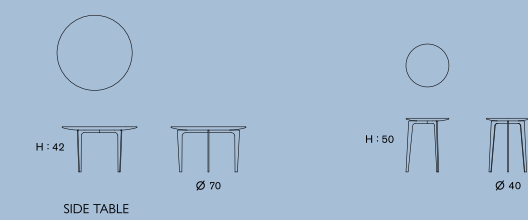

40 |

VELAR

Design: SHINSAKU MIYAMOTO

Frame and cushion in removable fabric and upholstered fixed leather
 Leg in steel powder coating with black and hairline stainless steel acrylic urethane coating with 6 colors, classic rose, shiny brass, antique brass, shiny bronze, antique gray and shiny hairline and stainless steel metallic with 2 colors, silkveil copper and silkveil gold
 Piping in artificial suede leather
 ----- Sewing scheme in leather



41 |

LIGHT FIELD

Design: SHINSAKU MIYAMOTO

Seat and back cushion in removable fabric and upholstered fixed leather

Outer panel in removable fabric, leather and upholstered fixed thick leather

Leg in steel powder coating with black and hairline stainless steel acrylic urethane coating with 6 colors,

classic rose, shiny brass, antique brass, shiny bronze, antique gray and shiny hairline

and stainless steel metallic with 2 colors, silkveil copper and silkveil gold

Thick leather available in black, taupe gray, ecru, amber, terracotta, burgundy, vintage brown and dark brown

----- Sewing scheme in leather

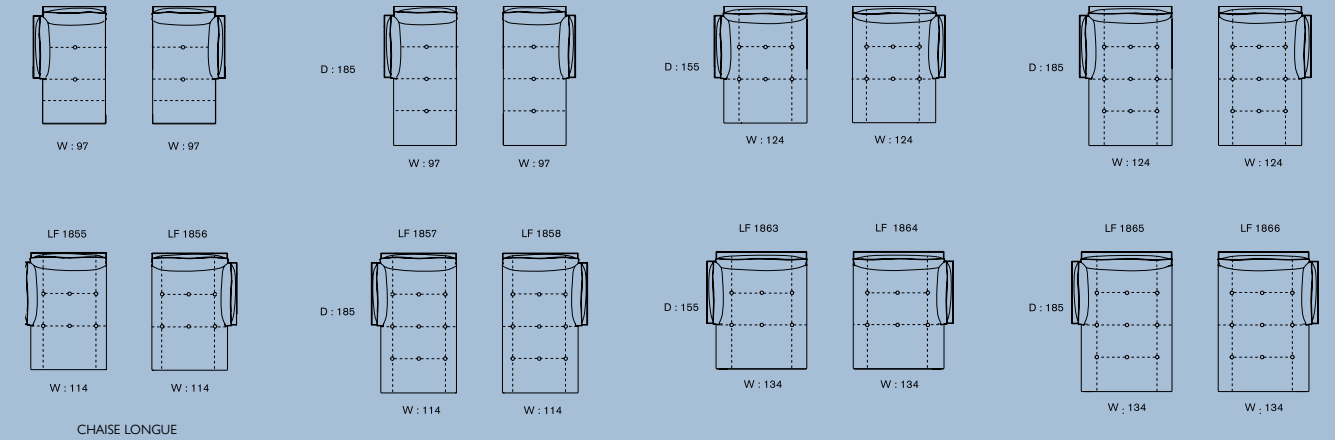
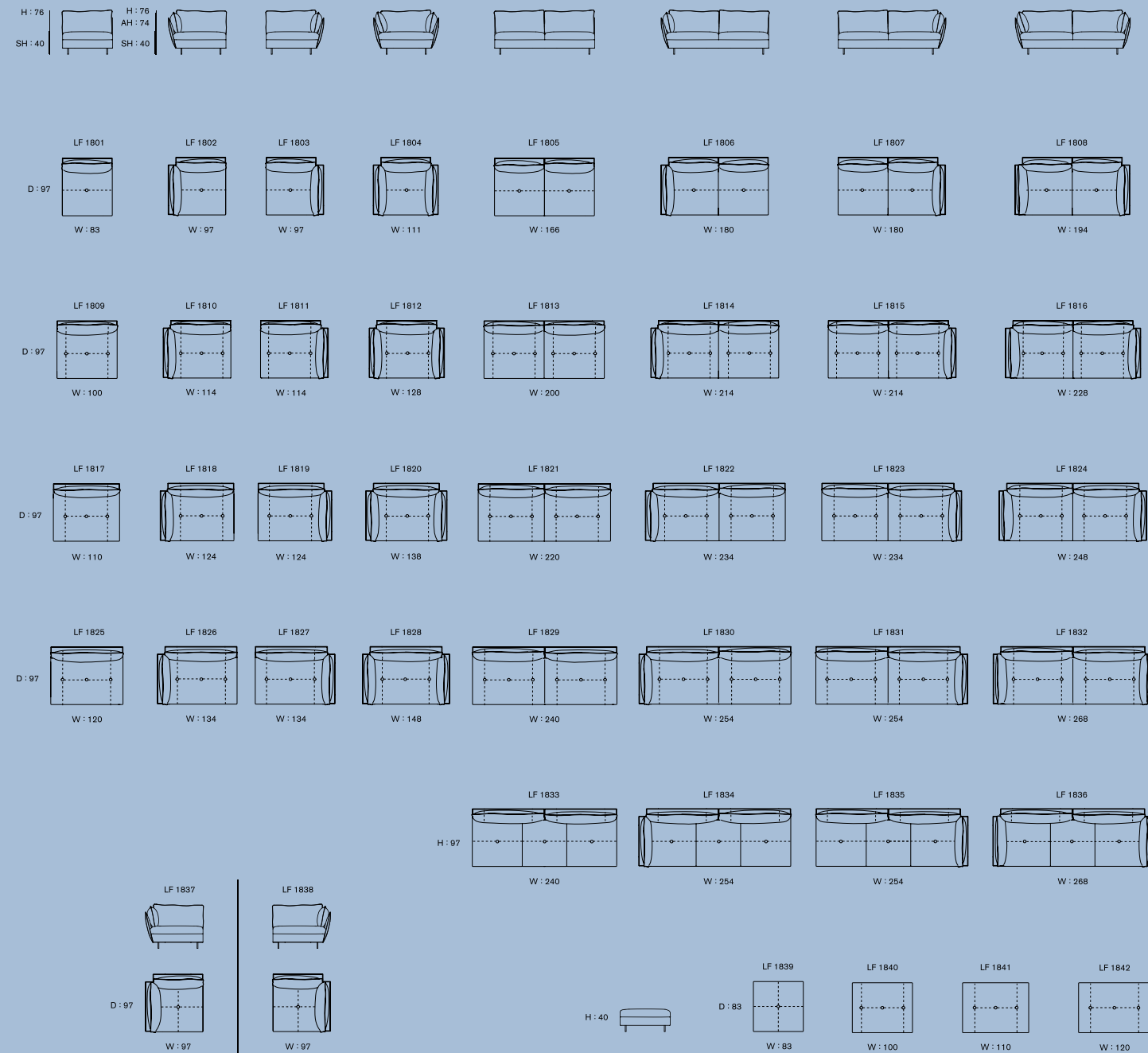

CHAISE LONGUE

40 |

DIANA

Design: SHINSAKU MIYAMOTO

Seat and back in removable fabric and leather

Frame cover in removable fabric and leather

and leather

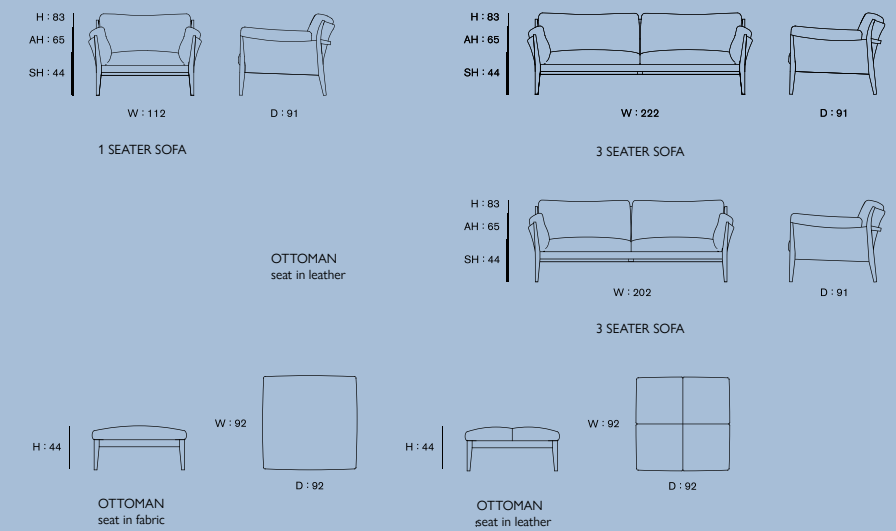

LEEWISE EXCLUSIVE
 Design: JUNICHIRO WATANABE & RITZWELL
 Seat and back cushion in removable fabric and leather
 Wooden base frame structure in white ash
 - - - - - Sewing scheme in leather

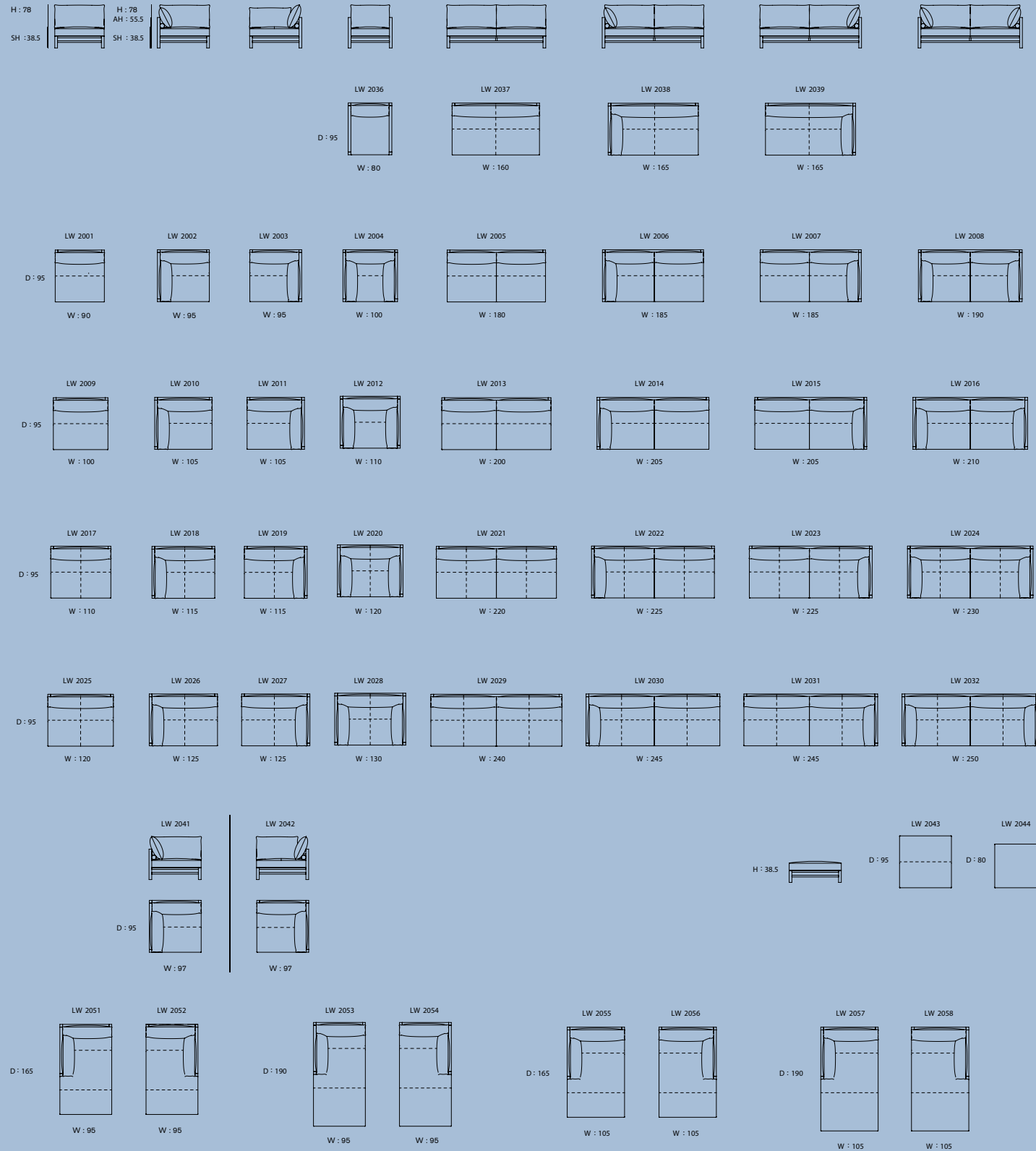

THE COLLECTION | TECHNICAL DATA

36 | JABARA SIDEBORD
 Design: SHINSAKU MIYAMOTO
 Body in walnut, oak
 Base in steel powder coating with black and hairline stainless steel acrylic urethane coating with 6 colors, classic rose, shiny brass, antique brass, shiny bronze, antique gray and shiny hairline and stainless steel metallic with 2 colors, silkveil copper and silkveil gold
 Door in sliding tambour door
 Front drawer in thick leather
 black, taupe gray, ecru, amber, terracotta, burgundy, vintage brown and dark brown

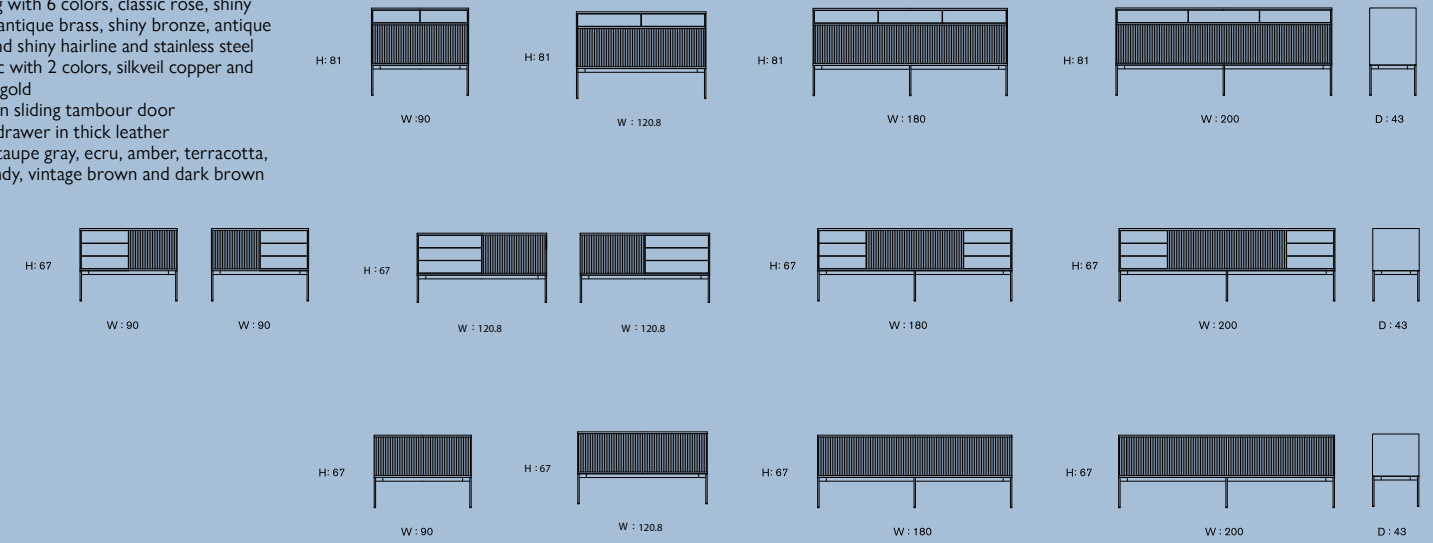

36 | JABARA AV BOARD
 Design: SHINSAKU MIYAMOTO
 Body in walnut, oak
 Base in steel powder coating with black and hairline stainless steel acrylic urethane coating with 6 colors, classic rose, shiny brass, antique brass, shiny bronze, antique gray and shiny hairline and stainless steel metallic with 2 colors, silkveil copper and silkveil gold
 Door in sliding tambour door and glass flap door

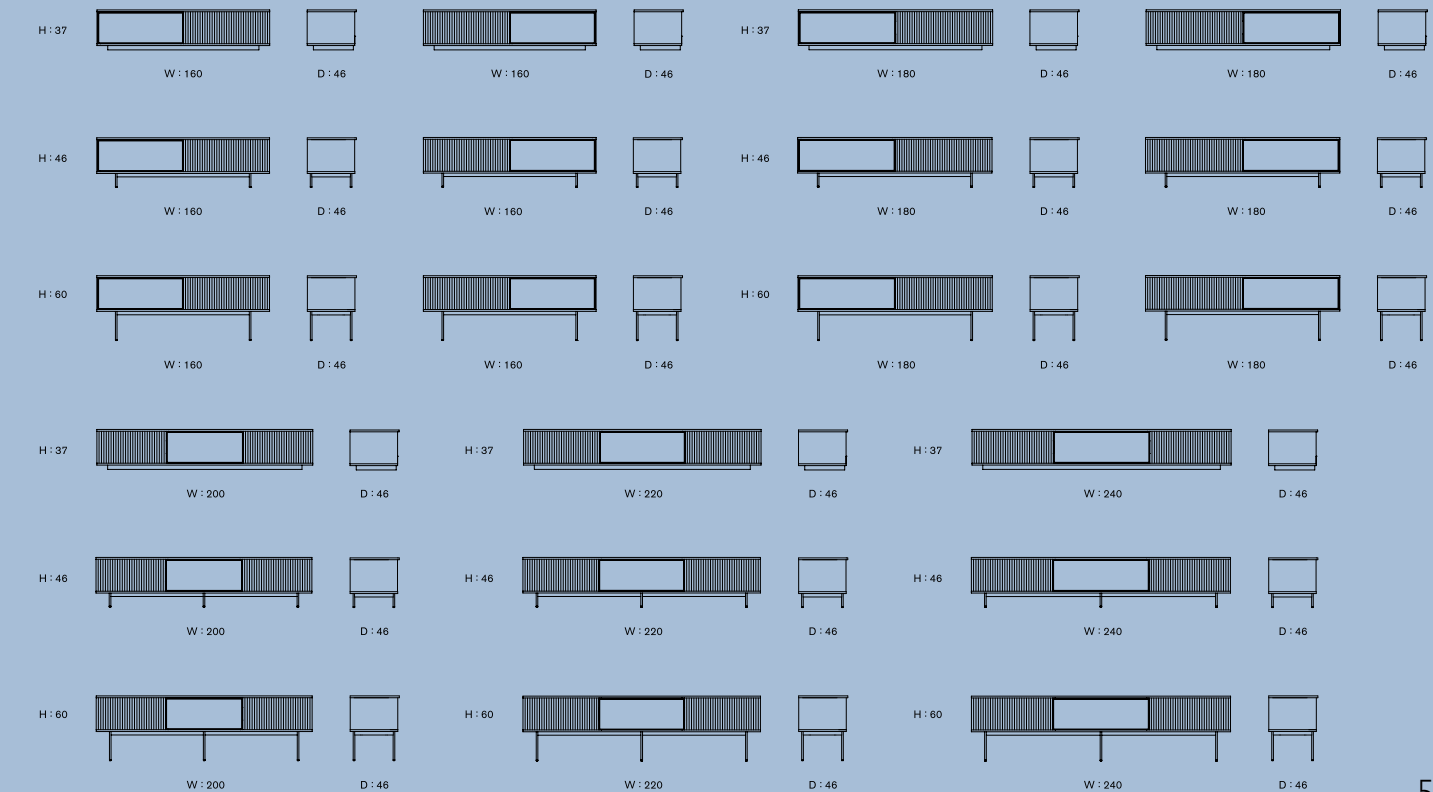

AWARDS



reddot design award



GERMAN
DESIGN
AWARD



DESIGN
AWARD



archiproducts
DESIGN AWARDS



GRAPHIC DESIGN
UNTITLED AGENCY MILANO

TEXTS
MICK CHISTOPOLOV

PHOTO CREDITS | 4, 22, 25, 26, 29, 30, 32, 37, 38
MARCO REGGI

PRINT
ARTI GRAFICHE MERONI

ENTER OUR WORLD



Ritzwell

RITZWELL & CO. | TOKYO | OSAKA | FUKUOKA
RITZWELL ITALIA S.R.L. | MILANO

info@ritzwell.com | www.ritzwell.com
follow us @ritzwell_official | @ritzwell_itoshima